

# RG-300 Drain-Well<sup>®</sup> Aluminum Abrasive Insert

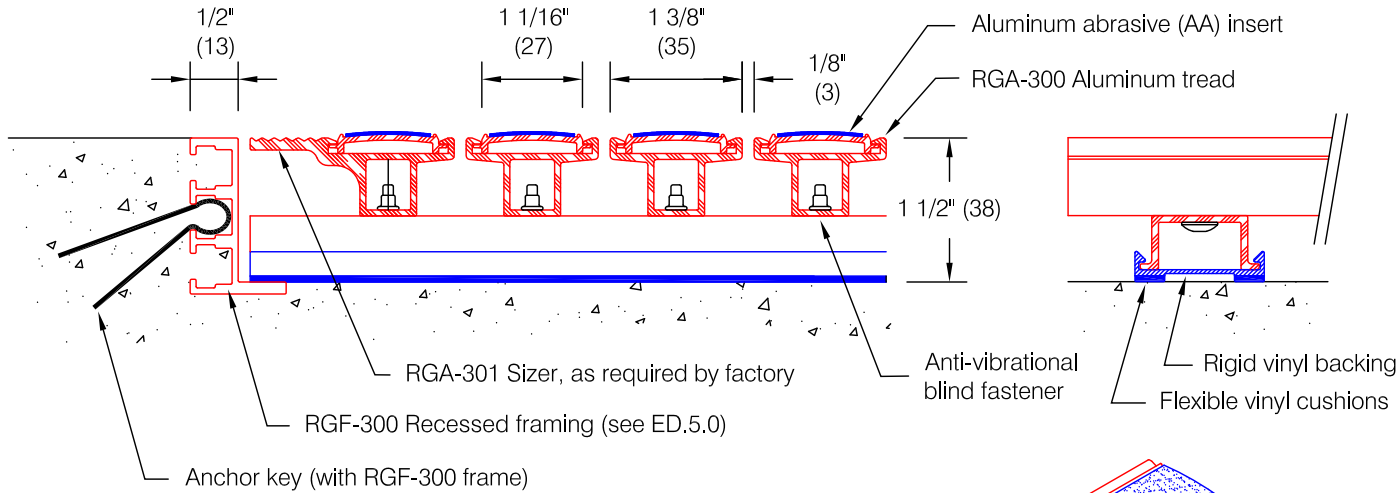

### Note On Dimensions:

\* Pawling requires that exact mat opening dimensions be provided. Factory will fabricate mats 1/4" (6) smaller than exact opening dimensions to allow for proper fit.

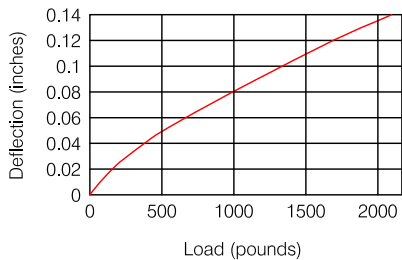

RG-300 Distributed Load Chart

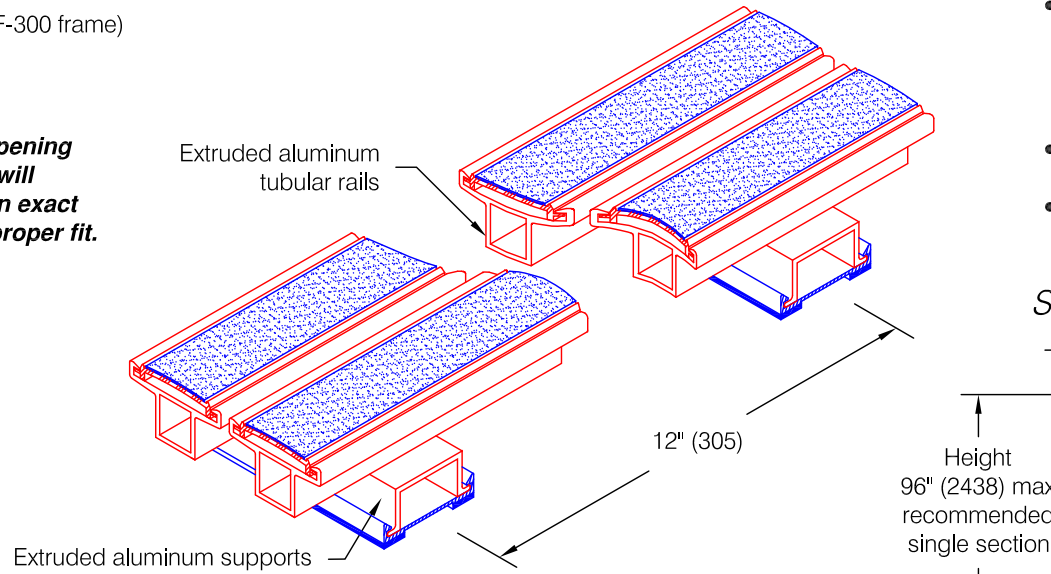

### Features:

- Extruded aluminum treads and cross supports alloy 6105-T5
- Continuous dual-durometer vinyl cushion for superior noise reduction
- 1 1/2" (38) deep for increased drainage ability
- Tubular tread rails for increased strength
- Anti-vibrational fasteners for sturdy, long-life service
- Single section width to 144" (3568)
- Aluminum abrasive insert: Extruded aluminum base with applied abrasive strip
- Static Coefficient of Friction (ASTM D-2047-82)  
 Dry: > 1.14, Wet: > 1.20

### Finishes:

- Aluminum tread:
  - Mill finish (standard) #405
  - Medium bronze anodized #404
  - Clear anodized #403
  - Black anodized #462
- Aluminum cross supports:
  - Mill finish #405
- Aluminum abrasive insert alloy 6105-T5:
  - Mill finish aluminum base (standard) #405
  - Abrasive from manufacturer's color samples

### Sectioning information:

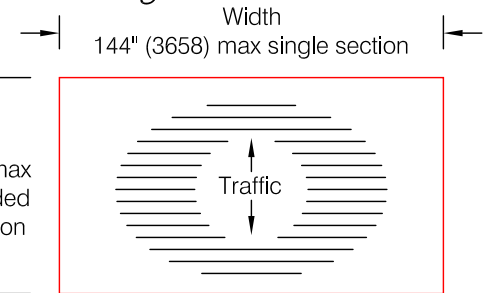

\* Mats over 48 square feet may require sectioning as determined by the factory

Pawling Corporation reserves the right to discontinue a design or modify an existing design without prior notice

Customer :	Project :	ED.26.0c
Architect :	Sales Rep :	