

## DFG-30 Door Frame Guard

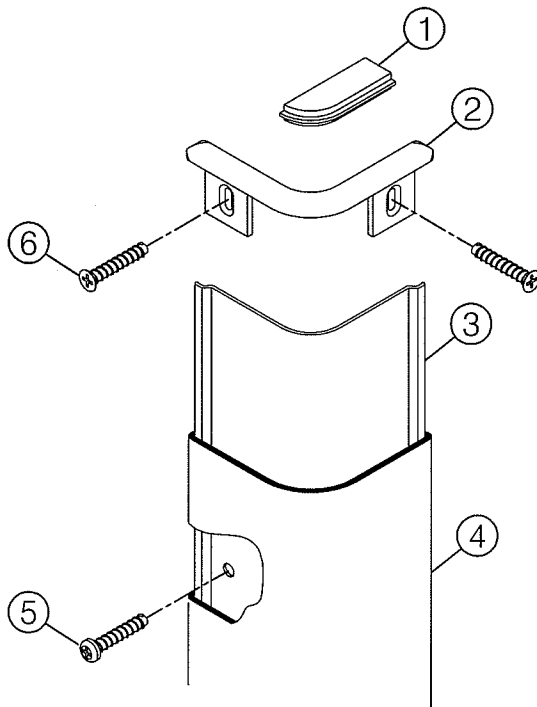
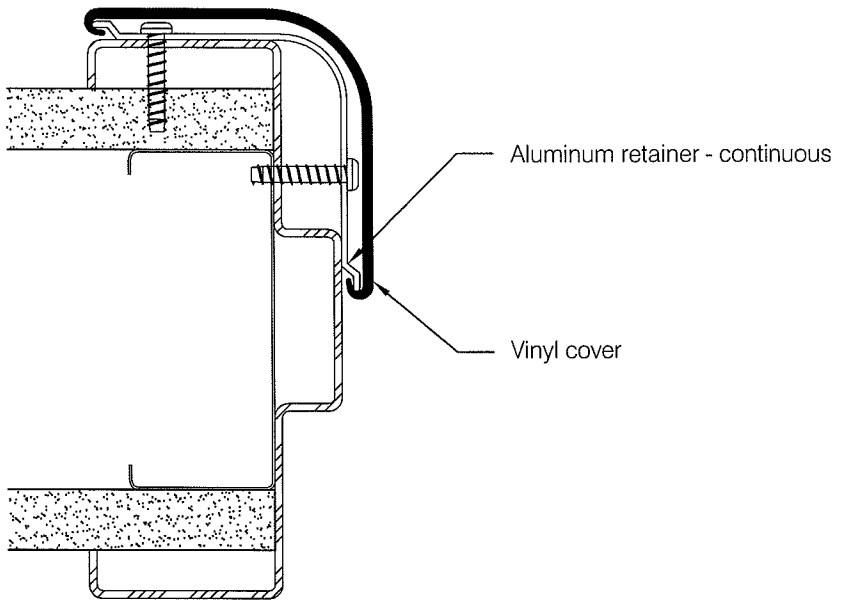

### Component Part Numbers:

- 1) TCI-32 Insert
- 2) TC-31 Top cap
- 3) CGA-30 Aluminum retainer
- 4) CGV-30 Vinyl cover
- 5) ABSS-88-0-441 Pan head screw #8
- 6) ABSS-89-0-441 Flat head screw #8

## DFG-30 Door Frame Guard Installation Instruction

- Step 1:** Measure the dimension from the face of the doorframe to the doorstep. Cut insert TCI-32 to fit this dimension, see **fig 1**. Both the aluminum retainer and snap on cover are pre-cut at the factory and require no further trimming.
- Important:** Store material in a clean dry place where the temperature is maintained above 50°F (10°C). Walls and rooms should be maintained at a minimum of 65°F (18°C) for at least 48 hours prior to installation. Acclimate materials to normal building conditions for at least 24 hours before cutting and installing.
- Step 2:** Position the bottom of the aluminum retainer 5/16" above the desired overall bottom of the installed doorframe guard to provide clearance for the molded closure cap, see **fig 2**.
- Step 3:** Hold the aluminum retainer firmly against the doorframe and drill a mounting hole in each wing visually centered in the length of the aluminum retainer using a #29 (.136") bit. Locate the holes in from the vertical edge as shown in **fig 3**. Stagger holes vertically to avoid fastener interference.
- Step 4:** Fasten retainer in place using two #8-32 pan head self-tapping machine screws. Hold aluminum firmly in place while installing the machine screws.
- Step 5:** Hold molded closure caps in place and drill hole using a #29 (.136") bit to align with mounting tabs. Drill through retainer and doorframe, see **fig 4**.
- Step 6:** Install the TCI-32 insert in the upper closure cap. The rib along the edge of the insert mates with the groove in the rear of the cap.
- Step 7:** Fasten closure caps in place using #8-32 flat head self-tapping machine screws. Hold cap firmly in place against aluminum while tightening.
- Important:** Upper closure cap is the cap with the TCI-32 insert. Orient cap and insert to conceal opening between the aluminum retainer and the doorframe.
- Step 8:** Snap extruded cover in place.

