

BR-400C Series Handrails

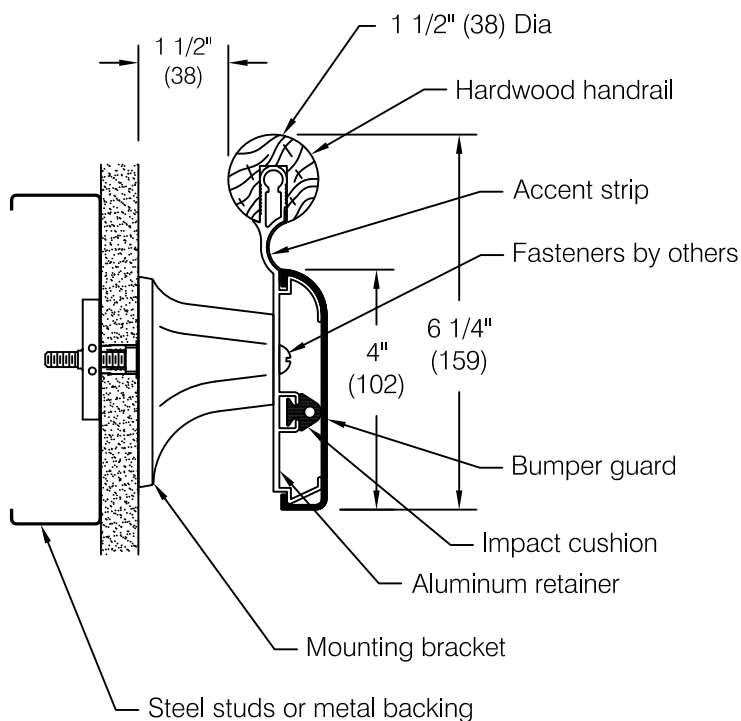

This installation instruction is applicable to:

BR-400C
 BR-400CG

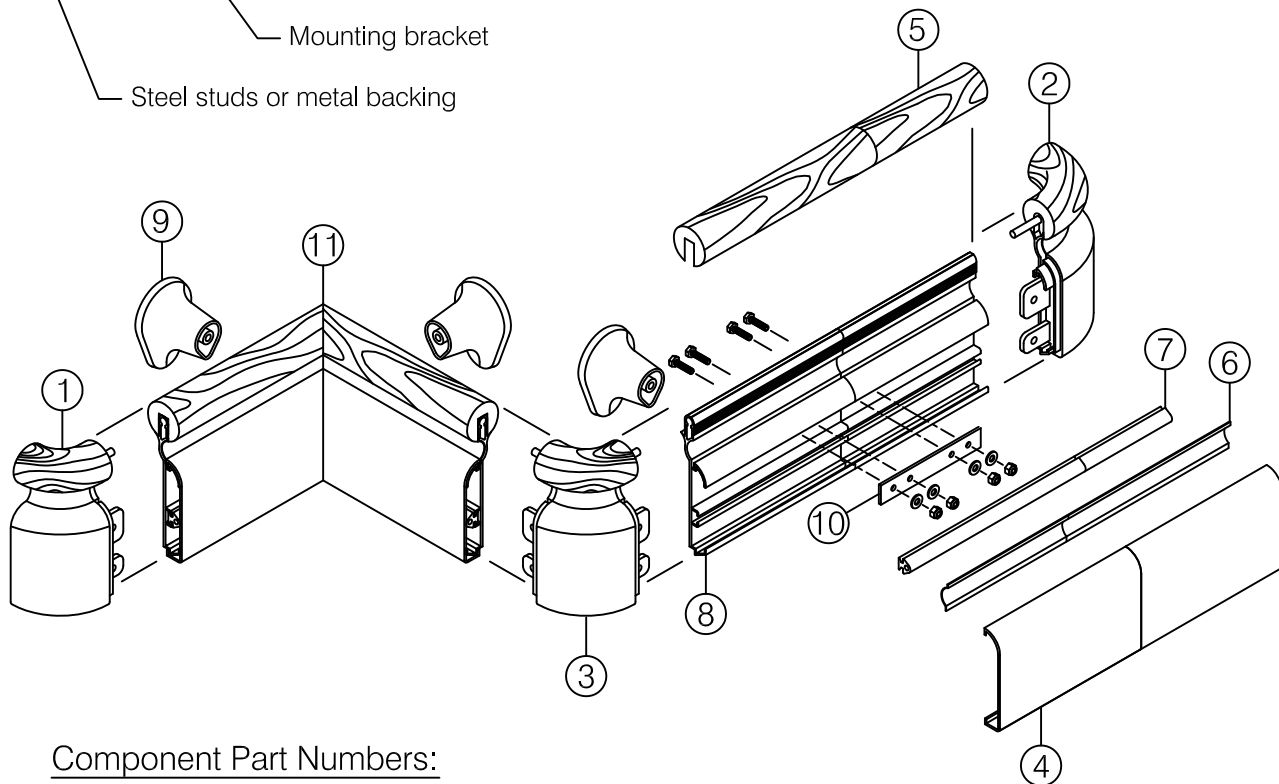

Component Part Numbers:

- | | |
|-----------------------------|-------------------------------|
| 1) BRL-425C Left return | 6) BRI-400C Accent |
| 2) BRR-425C Right return | 7) B-100 Impact cushion |
| 3) OBR-450C Outside corner | 8) BRA-400C Aluminum retainer |
| 4) Snap-on cover | 9) BR-108 Bracket |
| WGV-4 Standard texture | 10) SPL-400 Splice |
| WGVG-4 Grooved and textured | 11) Field miter inside corner |
| 5) BRW-400 Wood Handrail | |

- Step 1:** Determine top of handrail height and snap a chalk line 3 3/4" below for centerline of mounting hardware, see **fig 1**.
Important: Store material in a clean dry place where the temperature is maintained between 50°F (10°C) and 100°F (38°C). Walls and rooms should be maintained at a minimum of 65°F (18°C) for at least 48 hours prior to installation. Acclimate materials to normal building conditions for at least 24 hours before cutting and installing.
- Step 2:** Cut aluminum retainer. See **Cutting Adjustment Diagrams and Schedule** for adjustments to aluminum retainer length at wall returns, outside corners and inside mitre corners. Refer to **Minimum Layout Configurations** for additional information.
Important: All cuts must be square and deburred.
- Step 3:** Layout aluminum retainer "face up", mark and drill bracket mounting hole locations.
Bracket mounting holes must be spaced:
- Not to exceed 32" on center
 - 1 1/2" to 6" from end of aluminum retainer at returns and corner accessories
 - A minimum of 4" from end of retainer at splices to avoid interference with hardware shown in **fig 5**
 - To align with horizontal metal backer plate or metal studs (by others)
- Note:* Use groove in retainer to locate centerline for drilling, see **fig 2**
- Step 4:** Locate and drill holes for bracket mounting in wall construction using the aluminum retainer as a template or by careful measurement. Choice of hardware will dictate hole diameter.
- Step 5:** Insert molded accessories into end of retainer, press firmly to ensure molded part is seated squarely against the end of the retainer. Drill accessory mounting holes using the accessory as the template, see **fig 3**.
- Step 6:** Cut flexible impact cushion to length slightly shorter than the aluminum and slide into retainer, refer to **fig 6**.
- Step 7:** Attach molded returns and outside corners to retainer with accessory seated firmly and squarely while tightening. Fasten with 1/4" bolt, flat washer and nylon locknut provided.
Caution: Do not use a lock washer, use flat washer only. Always place a flat washer between nut and molded tab. Tighten to 10 ft-lbs maximum torque, see **fig 4**.
- Step 8:** Mount assembly to wall with the appropriate hardware according to wall construction. See **step 9** for splicing information.
Suggested hardware:
- Drywall: Toggler® brand toggle bolts
 - Masonry: Plastic Alligator® insert
- Step 9:** Refer to **fig 5** for splicing of aluminum retainer as required on longer handrail lengths. Always locate splice joints a minimum of 4" from bracket locations. For best results offset butt joint in cover from splice in aluminum retainer.
- Step 10:** Measure between accessories (corners and returns) and mitered corners. Cut bumper guard, accent strip and wood handrail accordingly. Care should be taken to select the straightest lengths of wood for the longest handrail spans. Select wood of similar grain and color to best match accessories and when joining sections end to end.
Important: All cuts must be square and deburred. Use 120 grit sand paper on wood being careful not to damage the finish
- Step 11:** Place accent strip in finger groove of rail, ID mark upward, see **fig 6**. Snap on the lower bumper guard.
- Step 12:** Layout wooden handrail. Ensure wood will span all aluminum retainer splices. Color the perimeter of all unfinished ends of the handrail using a stain pen or touch-up stain, see **fig 7**.
- Step 13:** Apply a 1/8" bead of construction adhesive (included) to the opposing faces of the wood handrail mounting groove, see **fig 8**.
Note: Do not apply adhesive to the top face of the mounting groove or wood will not seat properly on aluminum.
- Step 14:** Place wood handrail over the aluminum retainer starting at one end of the span.
- Step 15:** Align wood handrail at all returns, butt joints and corners, clamp if necessary. Clamp wood handrail to retainer on longer spans (or as required) using two wraps of packaging tape (protect wood and plastic finishes with paper). Remove all clamps and tape after adhesive has set.

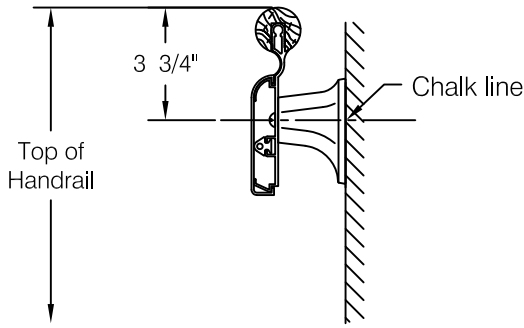

fig 1

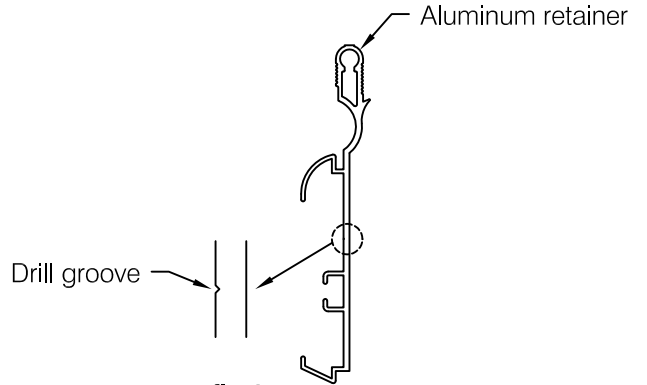

fig 2

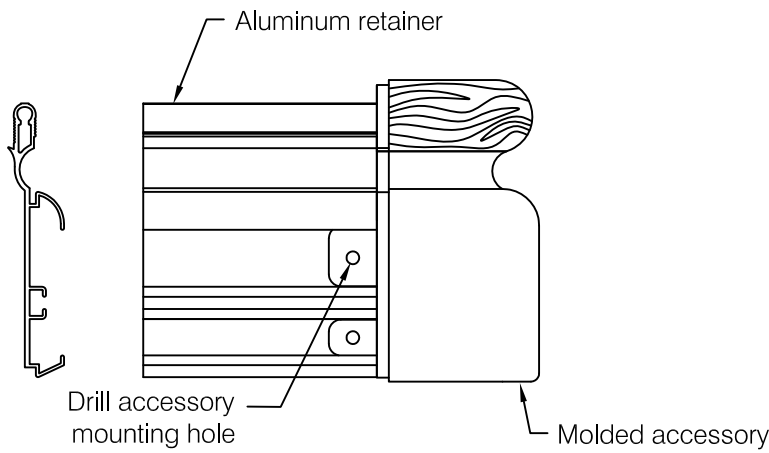

fig 3

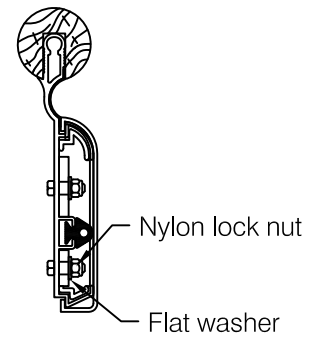

fig 4

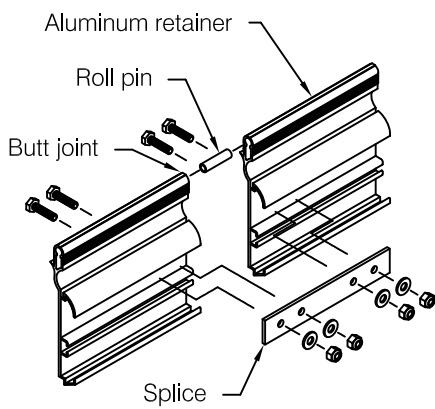

fig 5

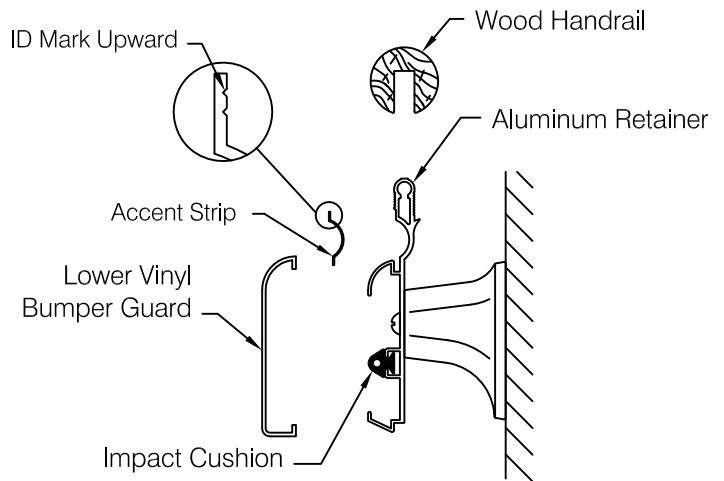

fig 6

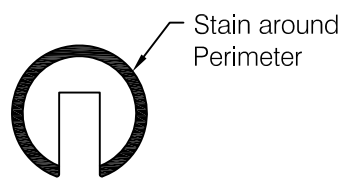

fig 7

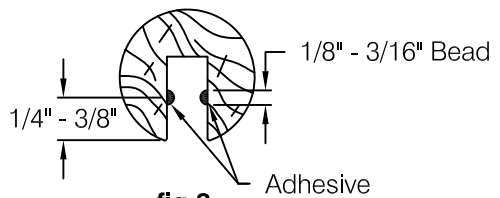
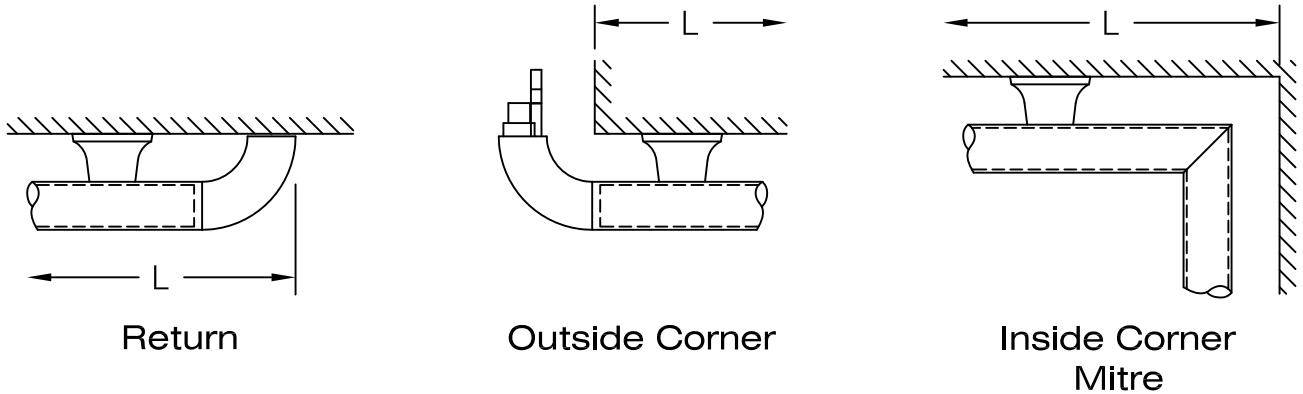

fig 8

Cutting Adjustment Diagrams and Schedule



	Aluminum Retainer	Vinyl Cover	Wood Handrail
Return	L - 3 3/8"	L - 3 1/8"	L - 3 1/8"
Outside Corner	L - 3/16"	L + 1/16"	L + 1/16"

Important: install aluminum retainer and molded accessories before cutting the snap-on cover.

Minimum Layout Configurations

