

EBT-30 Accent Rail - Textured

This installation instruction
is applicable to:

EBT-30

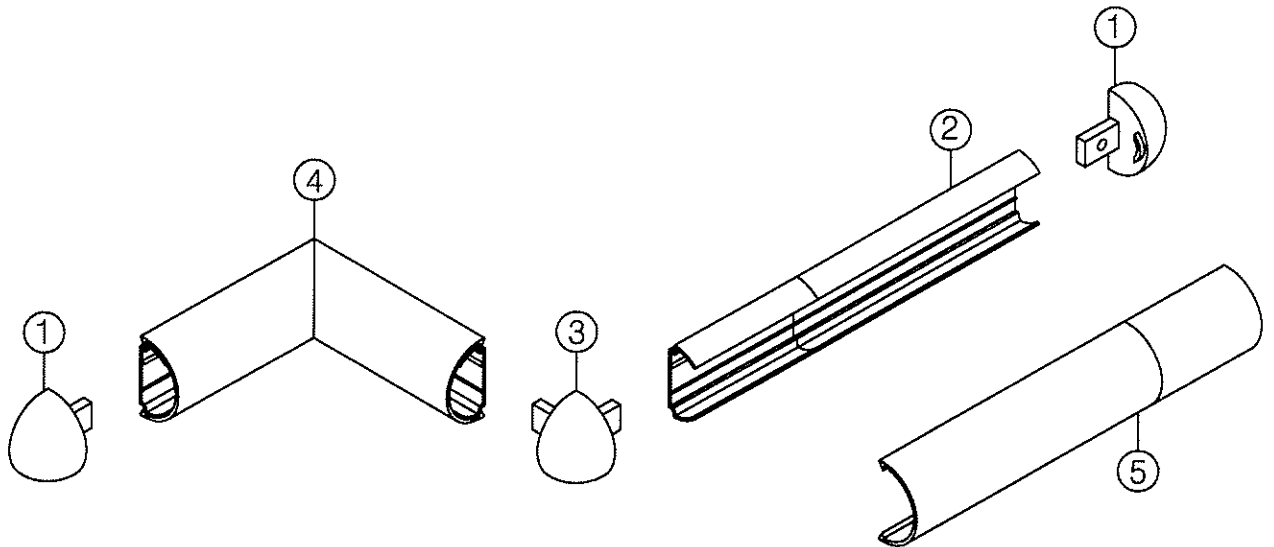
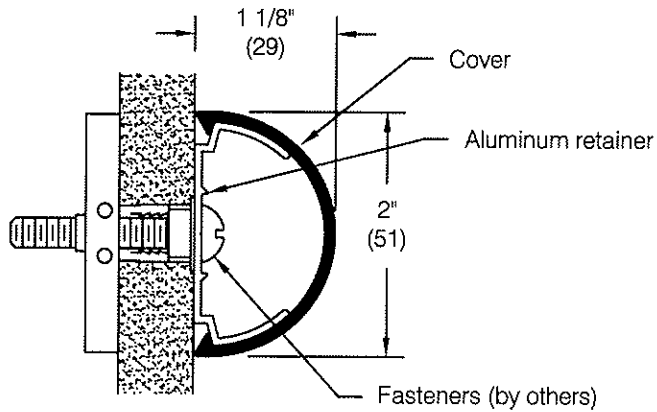

Component Part Numbers:

- 1) EBT-31 Left/Right end cap
- 2) EBRA-30 Aluminum retainer
- 3) EBT-32 Outside corner
- 4) Field mitered corner
- 5) EBTV-30-12-XXX Textured cover

- Step 1:** Determine top of wall guard and snap a chalk line 1/8" below to locate top of aluminum retainer, see **fig 1**.
- Important:** Store material in a clean dry place where the temperature is maintained between 50°F (10°C) and 100°F (38°C). Walls and rooms should be maintained at a minimum of 65°F (18°C) for at least 48 hours prior to installation. Acclimate materials to normal building conditions for at least 24 hours before cutting and installing.
- Step 2:** Cut aluminum retainer. See **Cutting Adjustment Diagrams and Schedule** for adjustments to aluminum retainer length at end caps, inside corners, and outside corners. Refer to **Minimum Layout Configurations** for additional information. Aluminum should be mitered to accommodate outside corners that are not 90° and all inside corners.
- Important:** All cuts must be square and deburred.
- Step 3:** Pre-drill clearance holes for wall mount fasteners in aluminum retainer along the V-Groove provided in the retainer, see **fig 2**. Use a #15 (.180") bit for #8 fastener or a #7 (.201") bit for #10 and 3/16" fasteners. Space holes at 16" on center. Adjust spacing to accommodate studs as necessary. Do not pre-drill at locations that will interfere with installation of molded accessories.
- Note:* Drill point fasteners may be used without pre-drilling aluminum on drywall installations having continuous metal backer or studs. Continue to pre-drill at locations where no backing or stud is available.
- Step 4:** Pre-drill for attachment of molded accessories by inserting accessory in end of retainer. Press firmly to ensure molded part is seated squarely against the aluminum.
- Drywall Installation:* Using the accessory as a template pre-drill clearance holes for mounting through to metal backer or stud or pre-drill pilot holes using #29 (.136") bit for #8 fastener or a #21 bit (.159") for #10 fastener for attaching accessories directly to aluminum, see **fig 3**.
- Masonry Installation:* Using the accessory as a template pre-drill clearance holes at mounting locations, see **fig 3**.
- Step 5:** Fasten aluminum retainer to wall using hardware listed below. Align top edge of retainer with chalk line.
- Important:** Begin installation of aluminum at corners allowing for molded accessories. Use the appropriate accessory as a spacing template. See **Cutting Adjustment Diagrams and Schedule** for additional information. Do not fasten through holes pre-drilled for installation of molded accessories until accessories are installed in **step 6**.
- Drywall Installation:* Fasten aluminum retainer to wall using hardware listed below. If it is necessary to install fasteners in locations where there is no metal backing or stud use pre-drilled aluminum as a template to mark and drill wall for Toggler® brand toggle bolts or plastic Alligator® insert in accordance with instructions provided with hardware.
- Masonry Installation:* Using the pre-drilled aluminum as a template, mark and drill the wall at all pre-drilled holes to accept plastic Alligator® insert or 3/16" Tapcon® or similar fastener. Drill in accordance with instructions provided with hardware.
- Suggested hardware :**
- Drywall with metal backing : #8 or #10 Drill point drywall screw or #8 or #10 drill point pan head or hex washer head sheet metal screw.
 - Drywall without stud or backing : Plastic Alligator® insert with #8 or #10 pan head or hex washer head sheet metal screw or 3/16" Toggler® brand toggle bolts with pan head machine screw.
 - Masonry : Plastic Alligator® insert with #8 or #10 pan head or hex washer head sheet metal screw or 3/16" hex washer head Tapcon®.
- Step 6:** Secure accessory components in place using hardware selected in **step 5**.
- Caution:* Use of a flat washer at accessory mounting tabs is recommended to prevent damage to molded part caused by excessive tightening of the fastener.
- Step 7:** Measure between accessories and cut the cover accordingly. Miter cut the cover for all angles not accommodated by the molded accessories. Cut cover so that it will span butt joints in aluminum retainer.
- Important:** All cuts must be square and deburred.
- Step 8:** Snap the cover in place. Install cover to span butt joints in aluminum retainer.

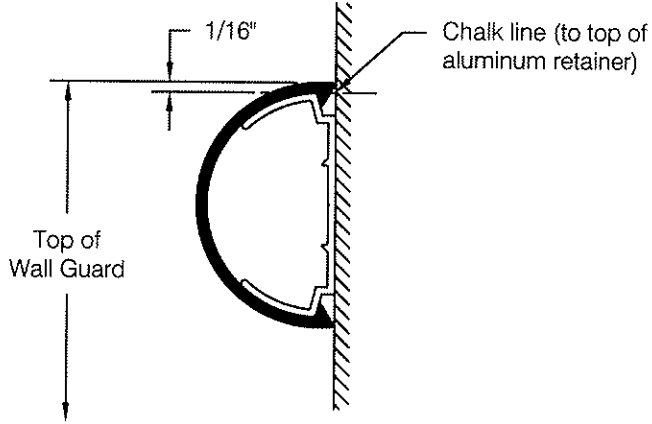

fig 1

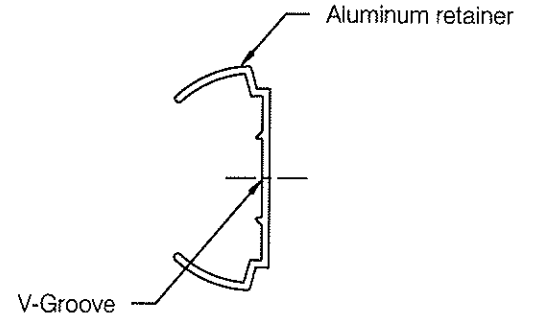

fig 2

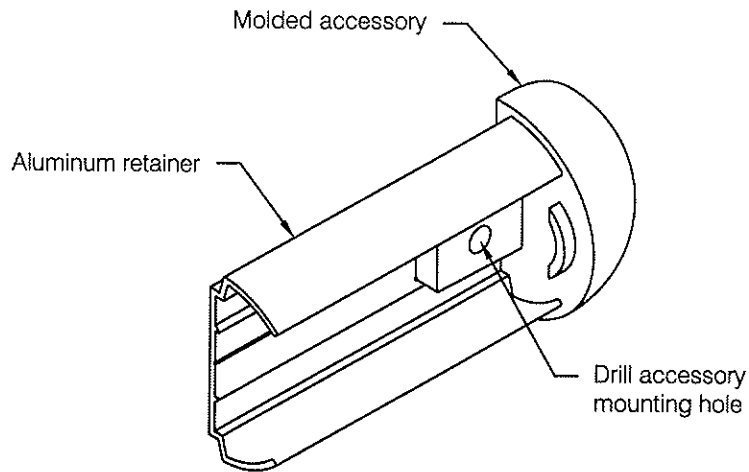
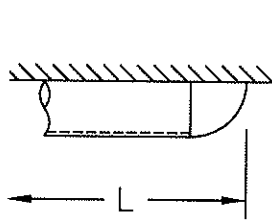
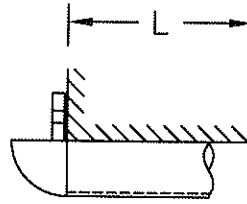

fig 3

Cutting Adjustment Diagrams and Schedule



End Cap



Outside Corner

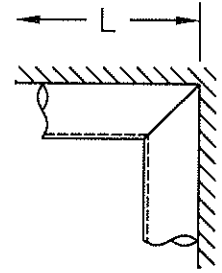

Inside Corner

	Aluminum Retainer	Vinyl Cover
End Cap	L - 1 3/16"	L - 1 3/16"
Outside Corner	L - 0"	L - 0"
Inside Corner	L - 0" (field miter)	L - 0" (field miter)

Important: install aluminum retainer and molded accessories before cutting the snap-on cover.

Minimum Layout Configurations

